

EX.00320.

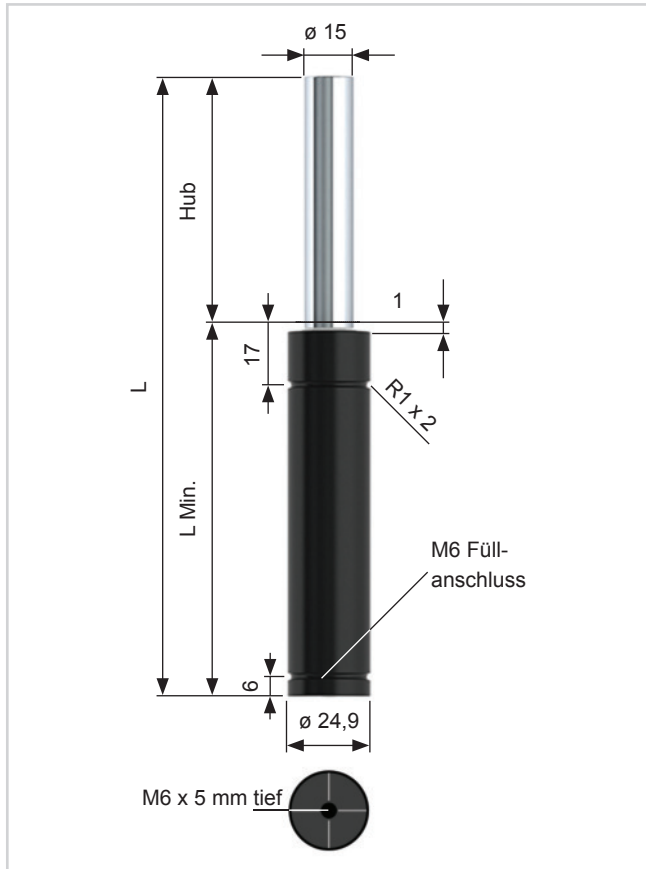

Artikel-Nr.: Typ/Hub	Kraft (daN)		L Min.	L	Gas Vol. (l)	Weight (Kg)
	Minimum	Maximum				
EX.00320.007	320	480	37	44	0,004	0,10
EX.00320.010		490	40	50	0,005	0,11
EX.00320.015		510	45	60	0,007	0,12
EX.00320.019		510	49	68	0,009	0,13
EX.00320.025		520	55	80	0,011	0,14
EX.00320.038		530	68	106	0,017	0,16
EX.00320.050		530	80	130	0,022	0,19
EX.00320.063		530	93	156	0,028	0,21
EX.00320.075		530	110	185	0,034	0,24
EX.00320.080		530	115	195	0,036	0,25
EX.00320.100		530	135	235	0,044	0,29
EX.00320.125		530	160	285	0,055	0,33

Hinweis:

Spezial-Hublängen auf Wunsch möglich.

Bestellbeispiel: Typ x Hub + Befestigung
EX.00320.050.FF



Nur Nitrogen verwenden!

Max. Druck: 150 Bar	Min. Druck: 20 Bar	Max. Kolbengeschwindigkeit: 1,6 m/Sek.
---------------------	--------------------	--

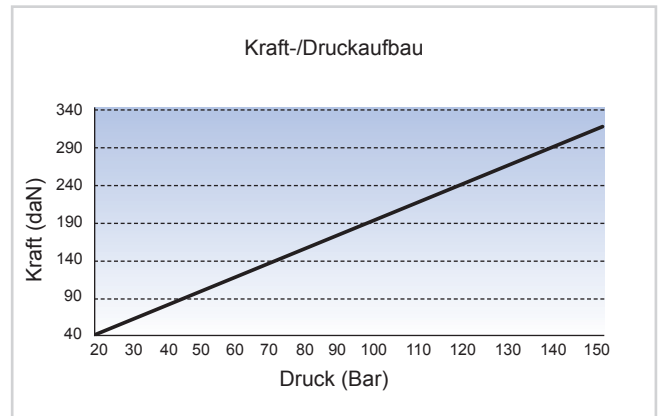
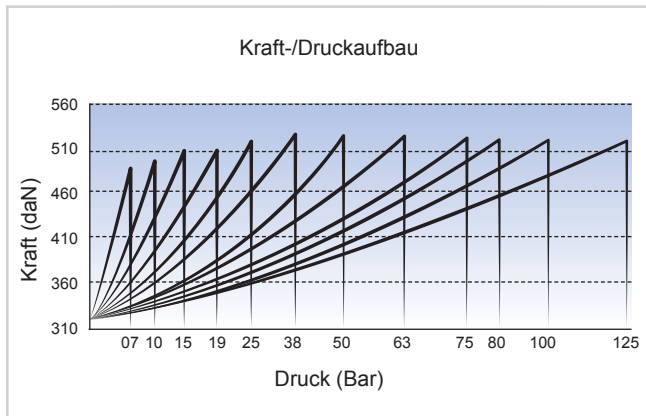

Befestigungsvarianten

(Alle Abmessungen in mm.)

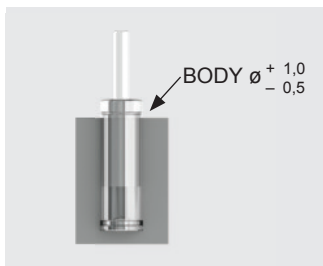

Sackloch



Front Flange FF



M6 Gewindebohrung /
Nur für Hub ab 25 mm.

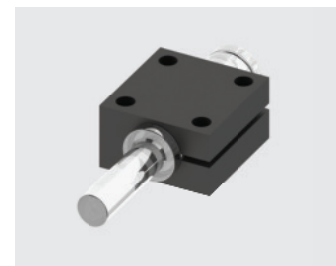

End Support 25 ES