

EX.02400.

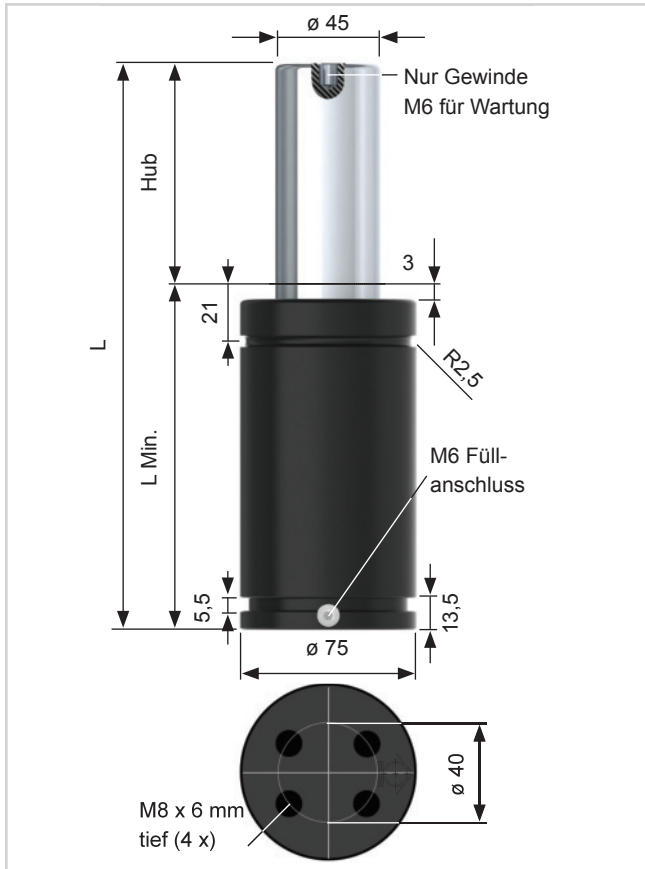

Artikel-Nr.: Typ/Hub	Kraft (daN)		L Min.	L	Gas Vol. (l)	Weight (Kg)
	Minimum	Maximum				
EX.02400.016	2400	3370	61	77	0,09	1,34
EX.02400.019		3460	64	83	0,10	1,38
EX.02400.025		3570	70	95	0,13	1,45
EX.02400.032		3640	77	109	0,16	1,56
EX.02400.038		3700	83	121	0,18	1,65
EX.02400.050		3780	95	145	0,23	1,84
EX.02400.063		3900	108	171	0,28	2,20
EX.02400.075		3930	120	195	0,33	2,26
EX.02400.080		3880	125	205	0,35	2,32
EX.02400.100		3920	145	245	0,43	2,66
EX.02400.125		3960	170	295	0,54	3,05

Hinweis:

Spezial-Hublängen auf Wunsch möglich.

Bestellbeispiel: Typ x Hub + Befestigung
EX.02400.050.FF

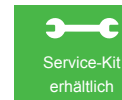

Nur Nitrogen verwenden!

Max. Druck: 150 Bar	Min. Druck: 20 Bar	Max. Kolbengeschwindigkeit: 1,6 m/Sek.
---------------------	--------------------	--

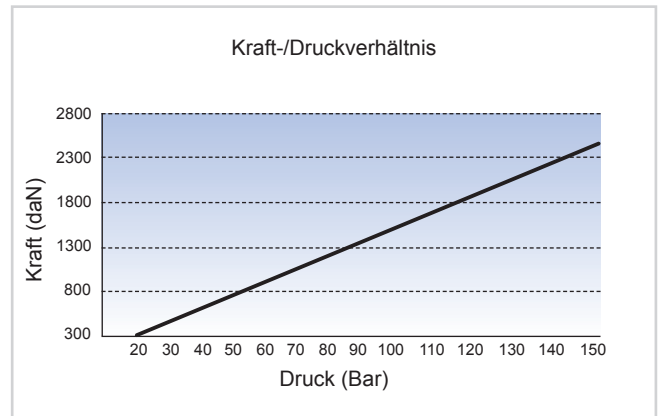
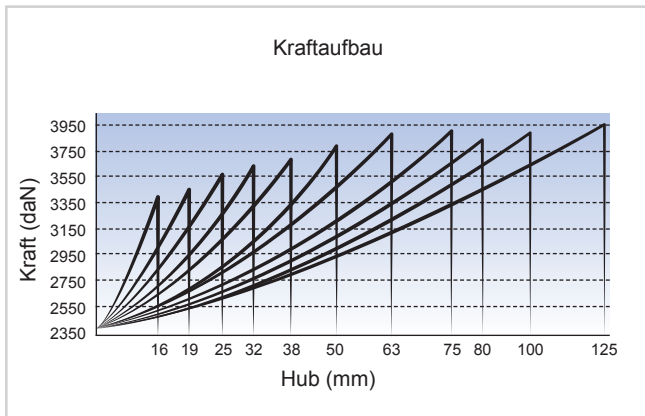

Befestigungsvarianten

(Alle Abmessungen in mm.)



4 x M8 Gewindebohrung



Square Front Flange 75 SFF



Front Flange 75 FF



Square Flange 75 SF



Base Plate 75 BP

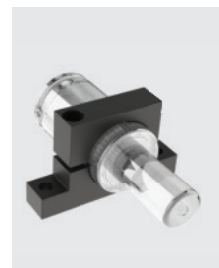

End Support 75 ES/75 HM