

# ISNG.10000.

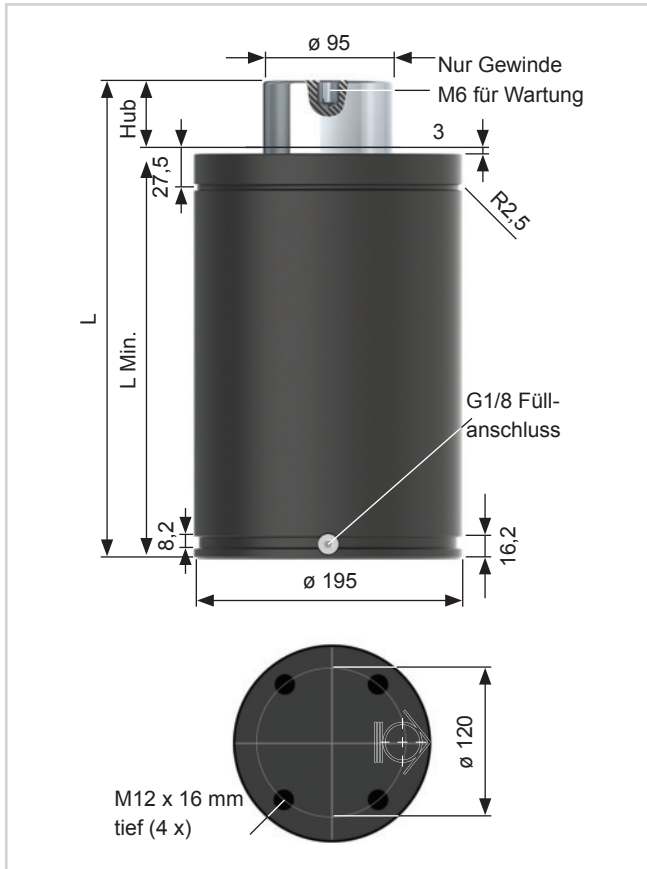

Artikel-Nr.: Typ/Hub	Kraft (daN)		L Min.	L	Gas Vol. (l)	Weight (Kg)
	Minimum	Maximum				
ISNG.10000.025	10000	13800	185	210	0,87	35,90
ISNG.10000.038		14300	198,1	236,2	1,13	37,60
ISNG.10000.050		14700	210	260	1,37	39,20
ISNG.10000.063		15000	223,5	287	1,64	41,00
ISNG.10000.080		15200	240	320	1,98	43,20
ISNG.10000.100		15600	260	360	2,38	45,80
ISNG.10000.125		15700	285	410	2,88	49,10
ISNG.10000.160		15800	320	480	3,59	54,50
ISNG.10000.200		16000	360	560	4,39	60,00
ISNG.10000.250		16000	410	660	5,40	66,50
ISNG.10000.300		16000	460	760	6,40	73,00

### Hinweis:

Spezial-Hublängen auf Wunsch möglich.

**Bestellbeispiel:** Typ x Hub + Befestigung  
ISNG.10000.050.FF

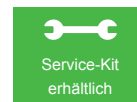

### Nur Nitrogen verwenden!

Max.  
Druck:  
150 Bar

Min.  
Druck:  
20 Bar

Max.  
Kolbengeschwindigkeit:  
1,6 m/Sek.

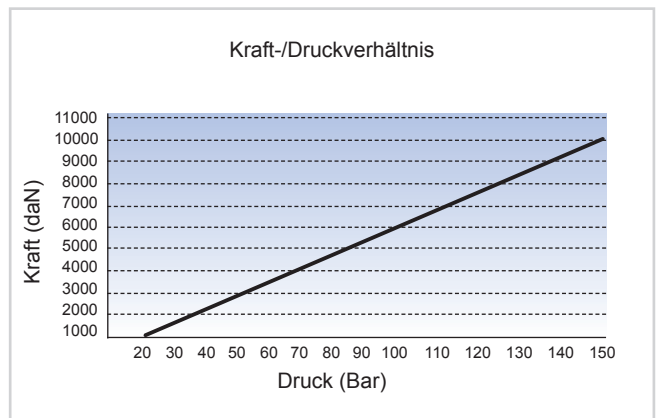
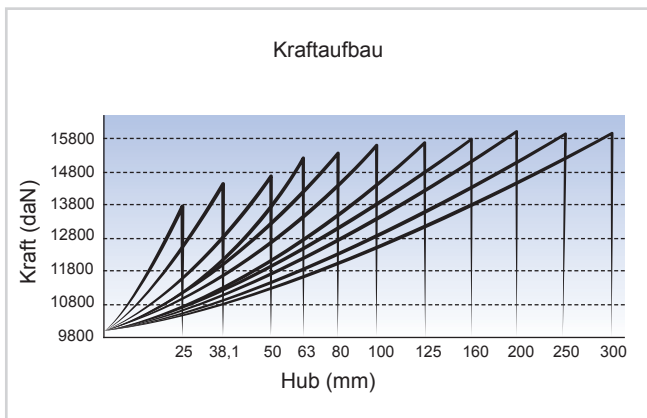

## Befestigungsvarianten

(Alle Abmessungen in mm.)



4 x M12 Gewindebohrung



Square Front Flange 195 SFF



Front Flange 195 FF



Square Flange 195 SF



Base Plate 195 BP