

SCHNELLWECHSELSCHNEIDSTEMPEL, SCHWERE BELASTUNG, O. ABDRÜCKSTIFT

Artikel-Nr.: S810.D.L / Artikel-Nr.: S81...D.L.L₂.P.w



Werkstoff:

HSS

Härte: Schaft 64 ± 2 HRC

Ausführung:

Schaft und Schneiddurchmesser feinstgeschliffen.

Sonderanfertigung auf Anfrage.

Bestellbeispiele: S810.D.L = S810.16.100

S81...D.L.L₂.P.w = S812.16.100.19.1200.0800

S810.

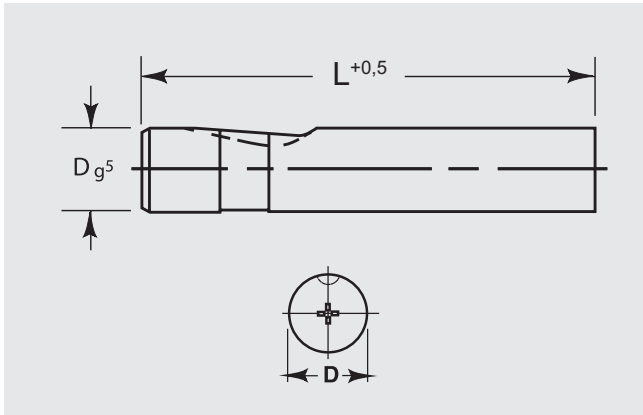

S81..

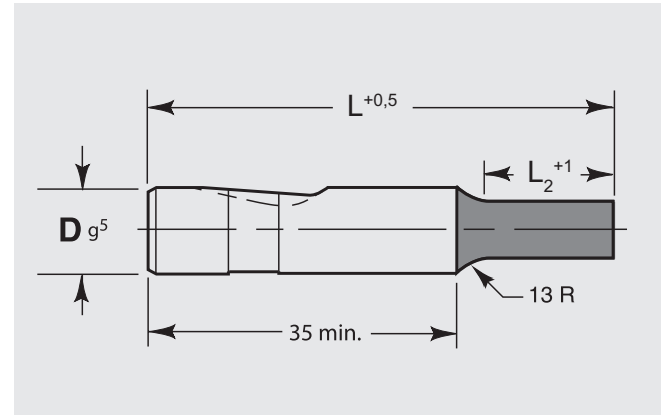

Form (Toleranz ±0,01)

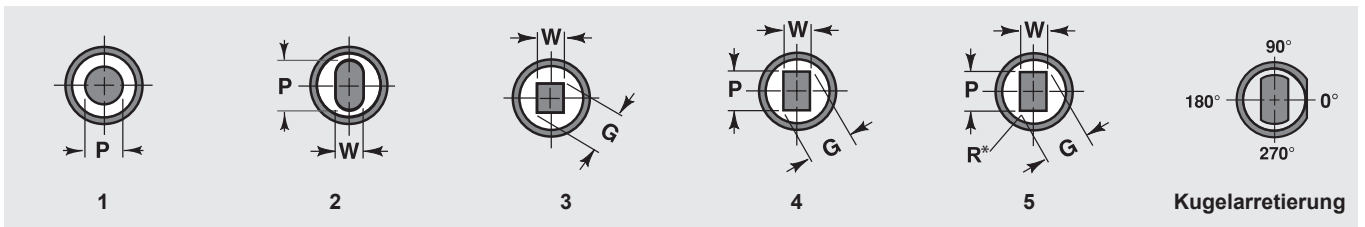

Kugelarretierung

* nach Kundenwunsch

D	L ₂			L					Absatz		
									Rund P	Form	
	Std.	Alt.	Alt.	63	71	80	90	100		Min. W	Max. P/G
10	19	10		•	•	•	•	•	2,1 – 9,97	2,1	9,97
13	19	13		•	•	•	•	•	5 – 12,97	4,5	12,97
16	19	13		•	•	•	•	•	8 – 15,97	6	15,97
20	19	13		•	•	•	•	•	12 – 19,97	8	19,97
25	19	13	25		•	•	•	•	16 – 24,97	10	24,97
32	19	13	25		•	•	•	•	24 – 31,97	12,5	31,97
40	25	19	30			•	•	•	30 – 39,97	14	39,97